

- DSP\_MCUTEST(2:0)
- USB\_DIG(6:0)
- GENIO(52:0)
- IACCDIF(5:0)
- RFAUX(1:0)
- PWRONX
- SIMIF(3:0)
- HOOKINT

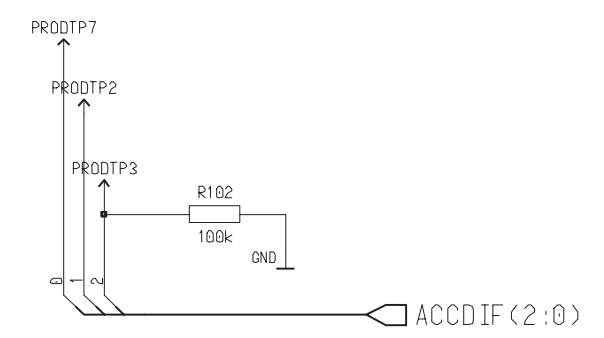

- ◊ SLOWAD(6:0)
- ◊ GENIO(52:0)
- ◊ PUSL(3:0)
- ◊ UIDRV(5:0)
- ◊ HOOKINT
- ◊ IHF(1:0)
- ◊ AUDUEMCTRL(5:0)

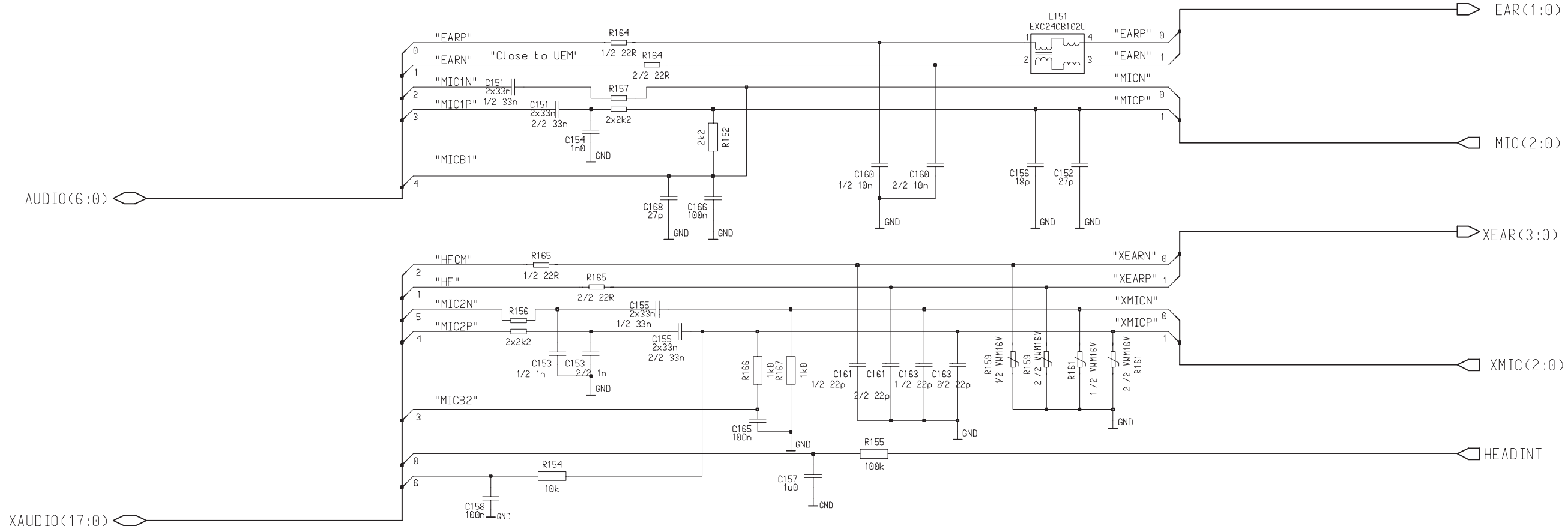

Used Refs: C151-C153, C155- 166  
 R151, 153-R160, 162, 163  
 Z151-Z152

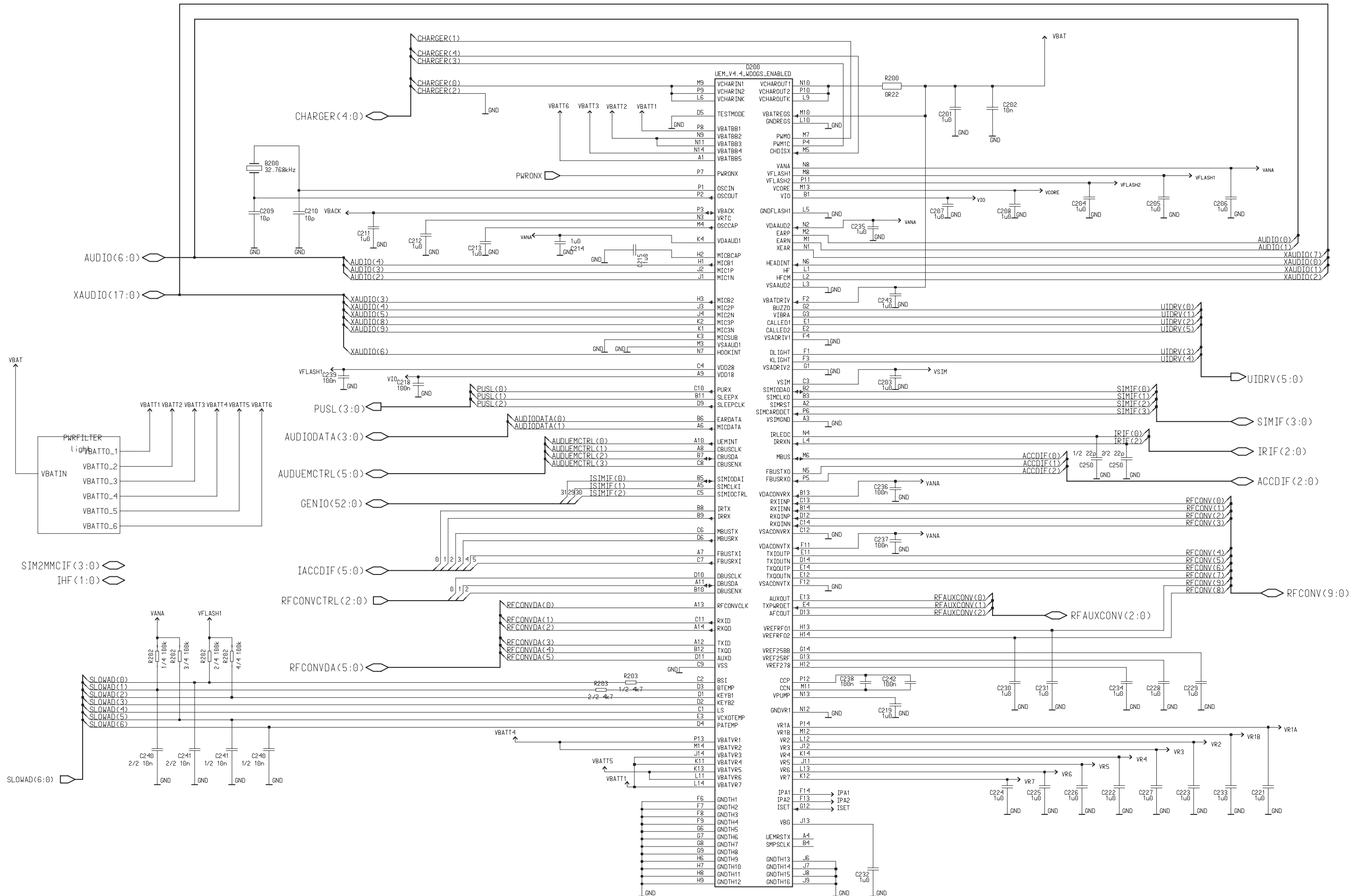

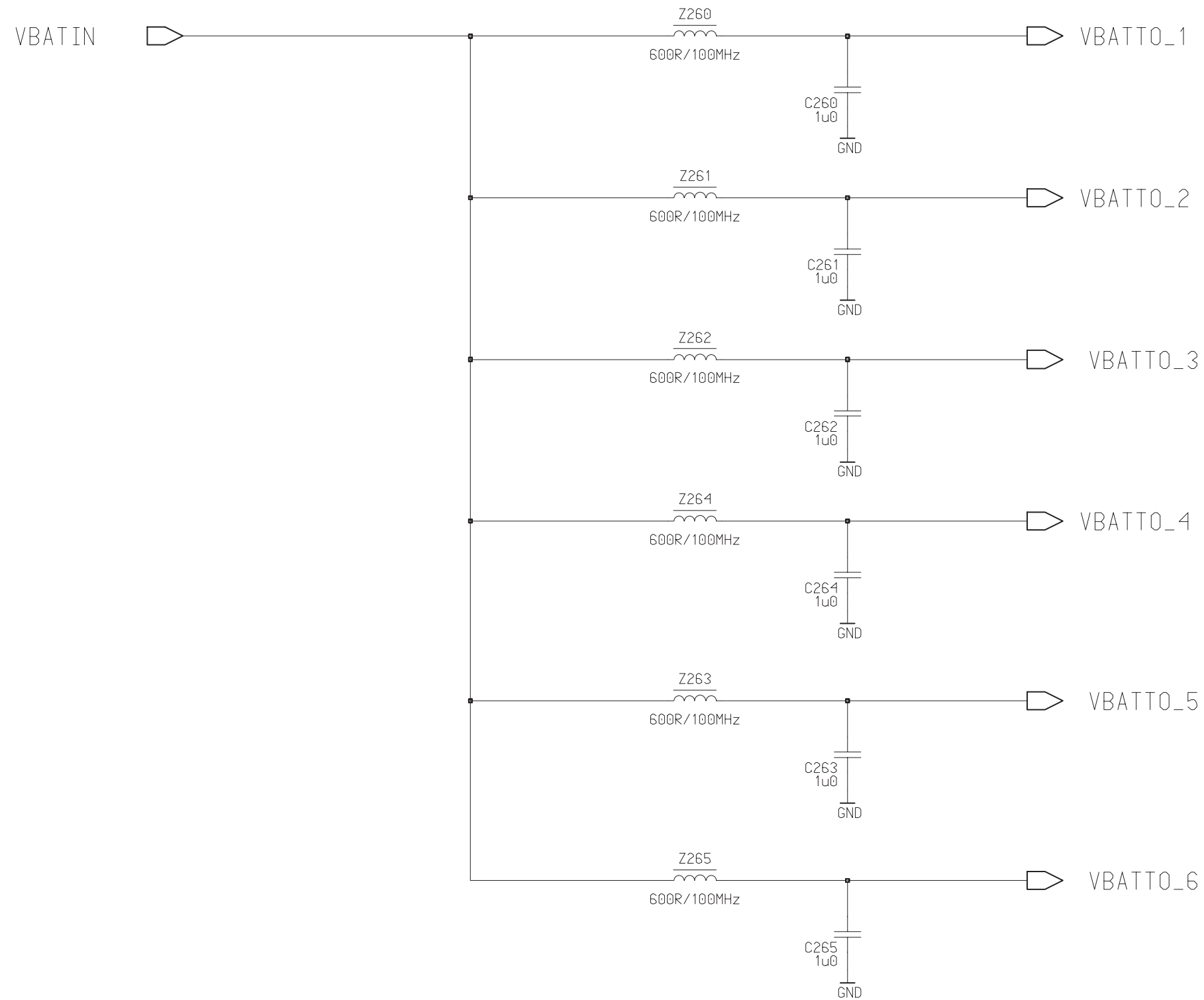





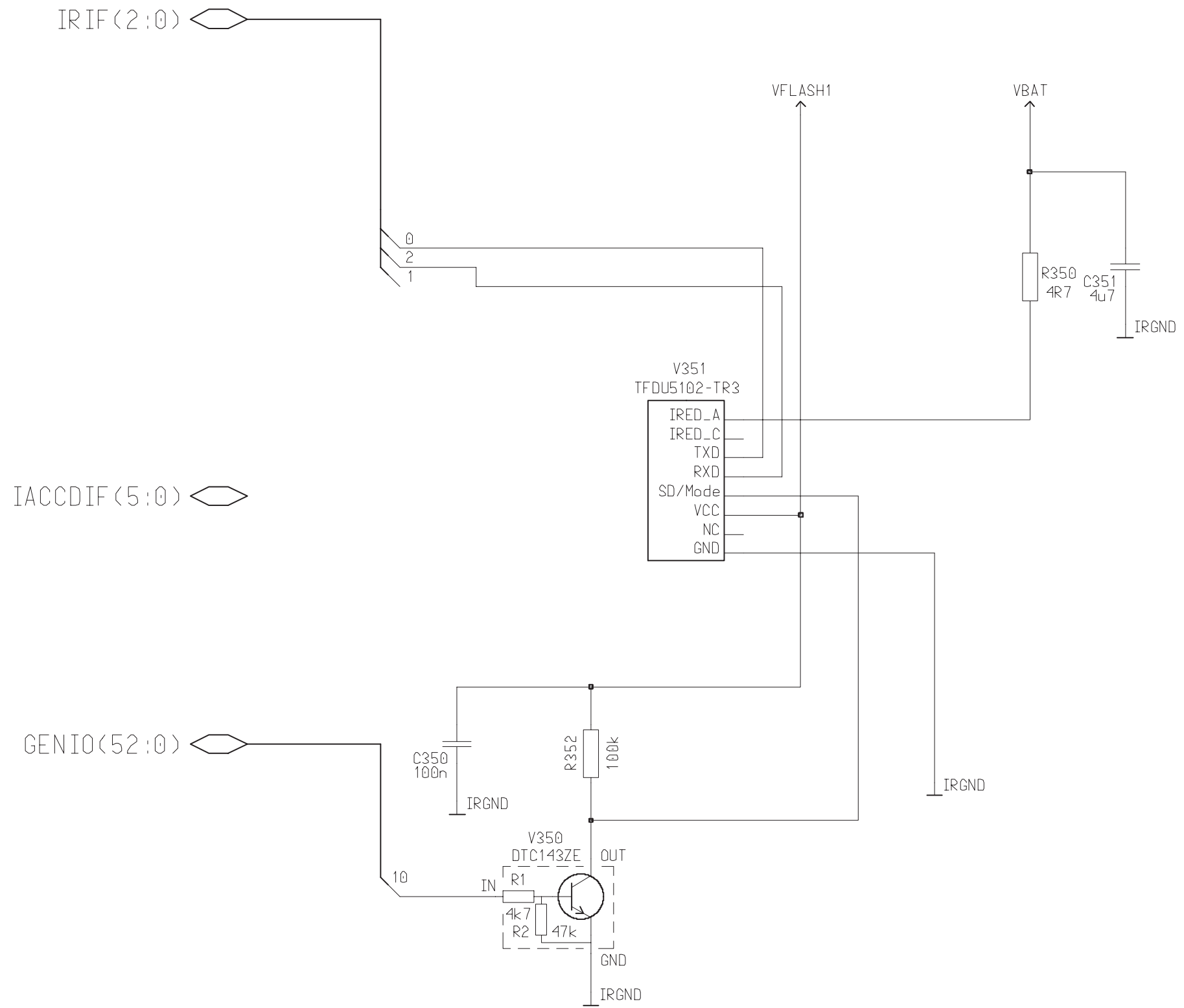

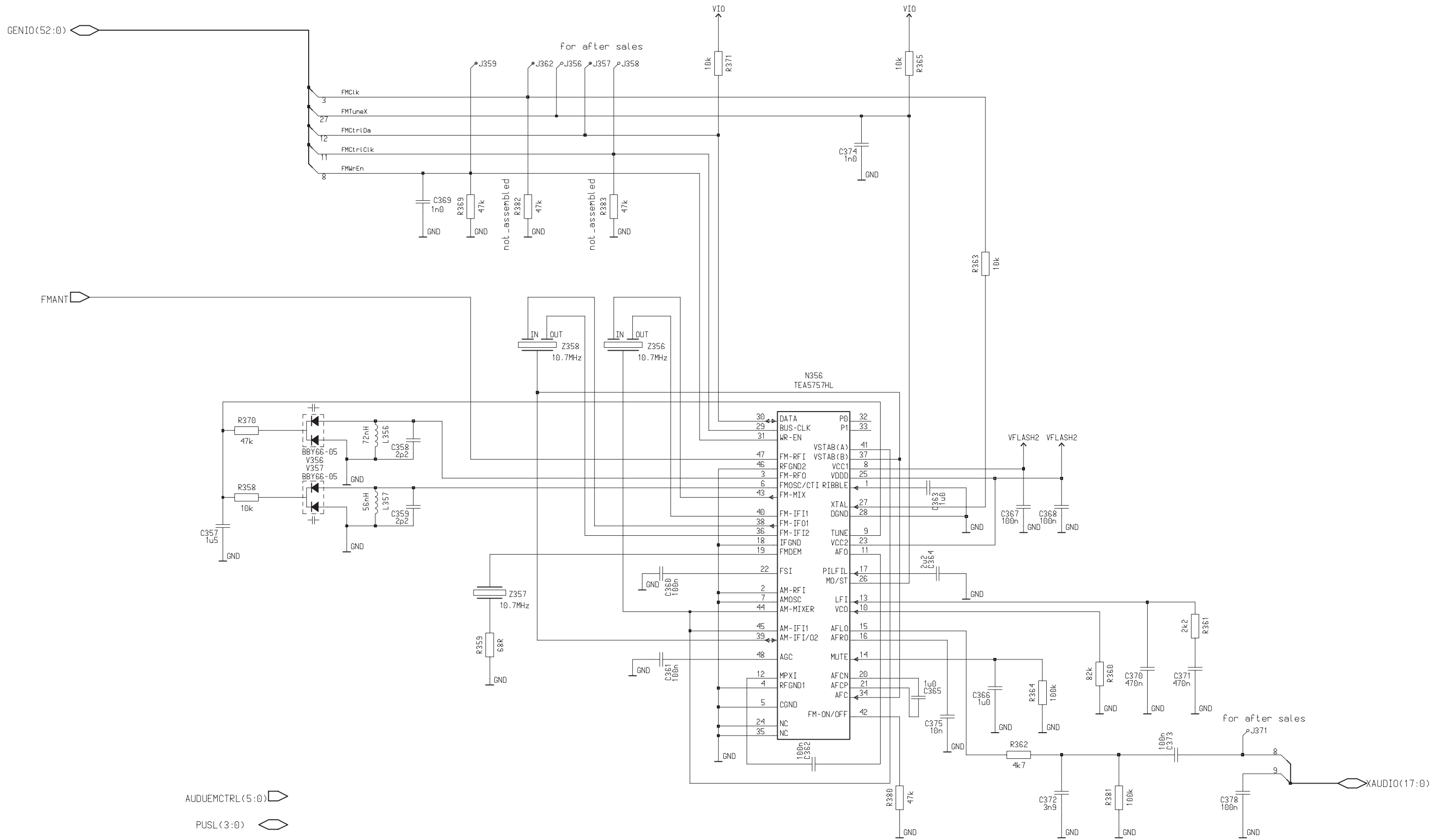

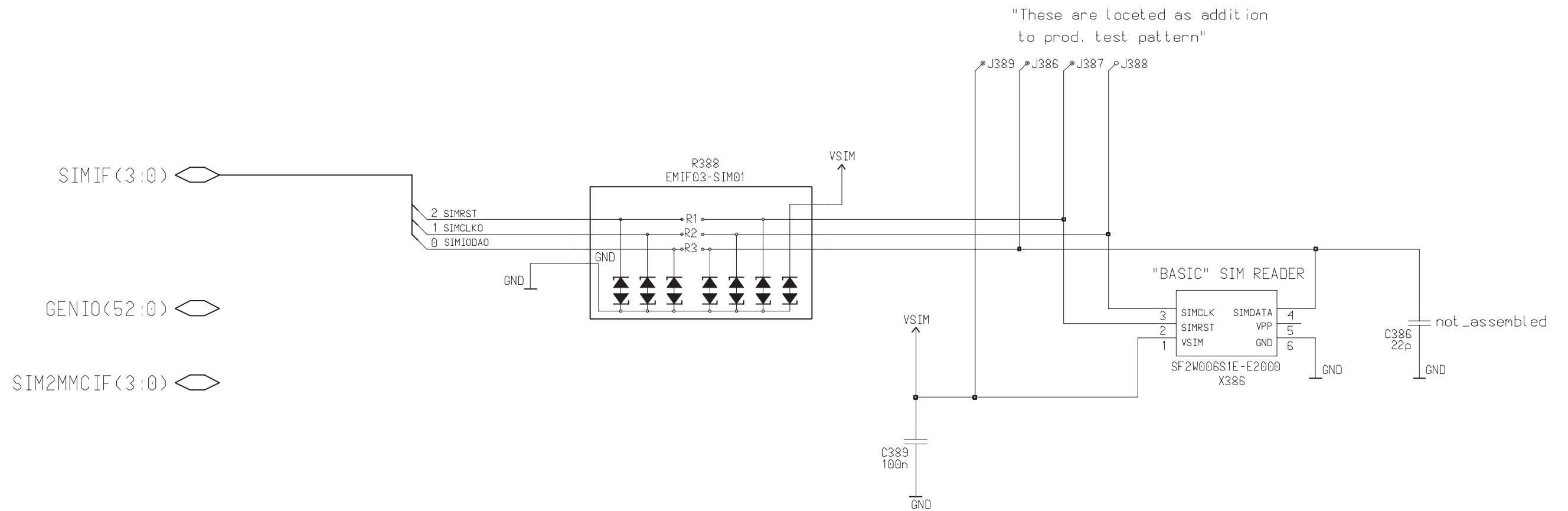

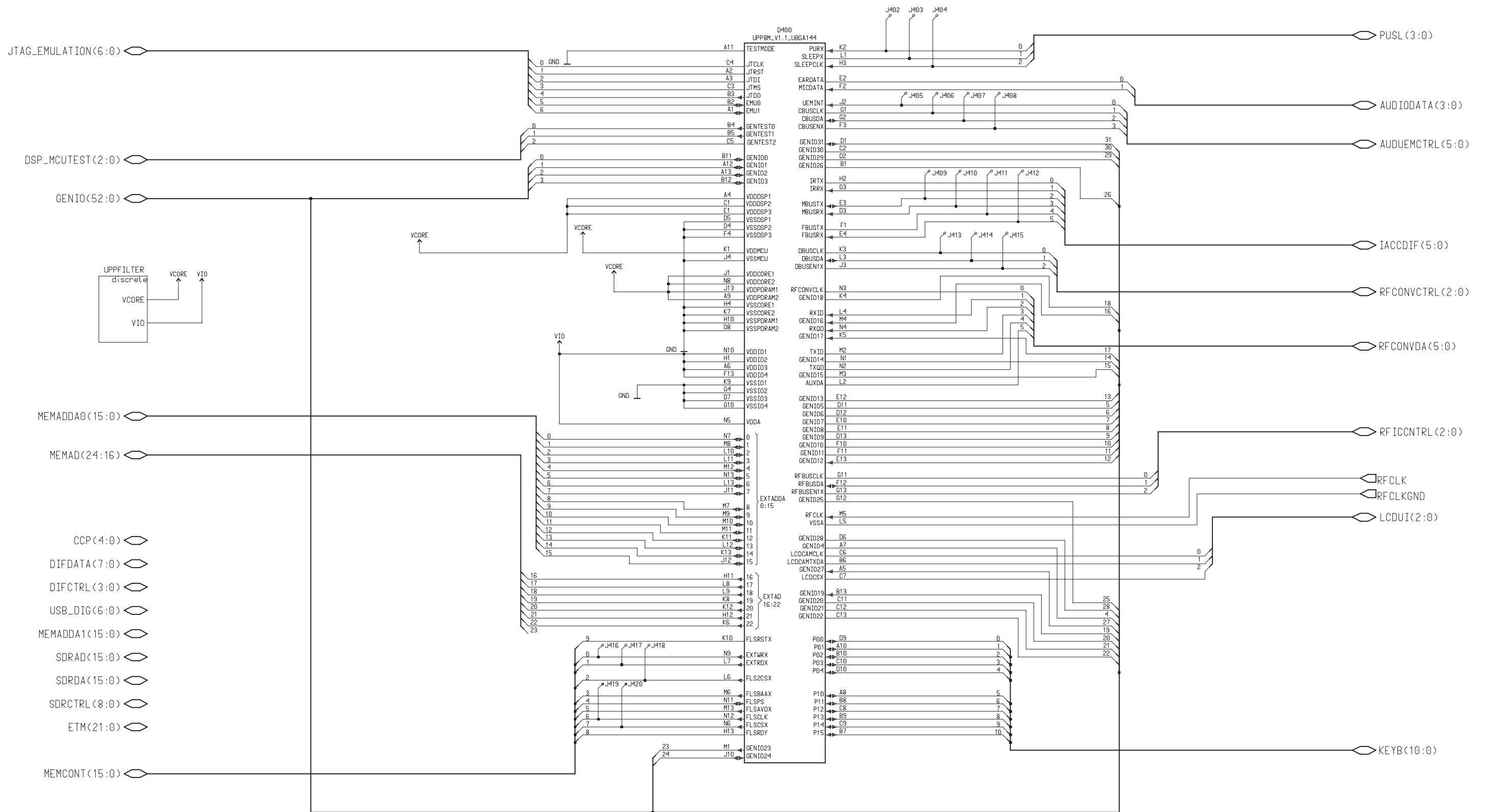

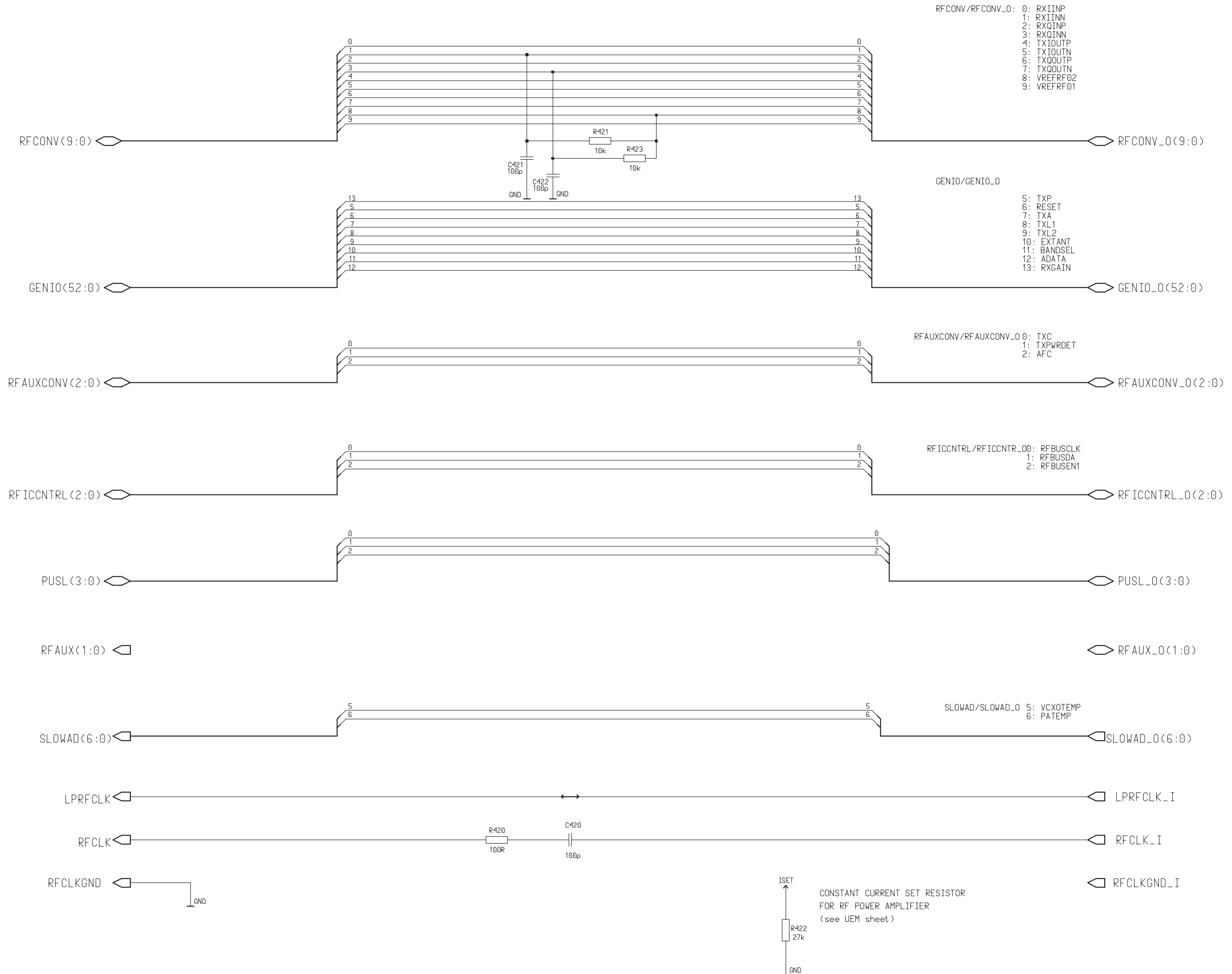

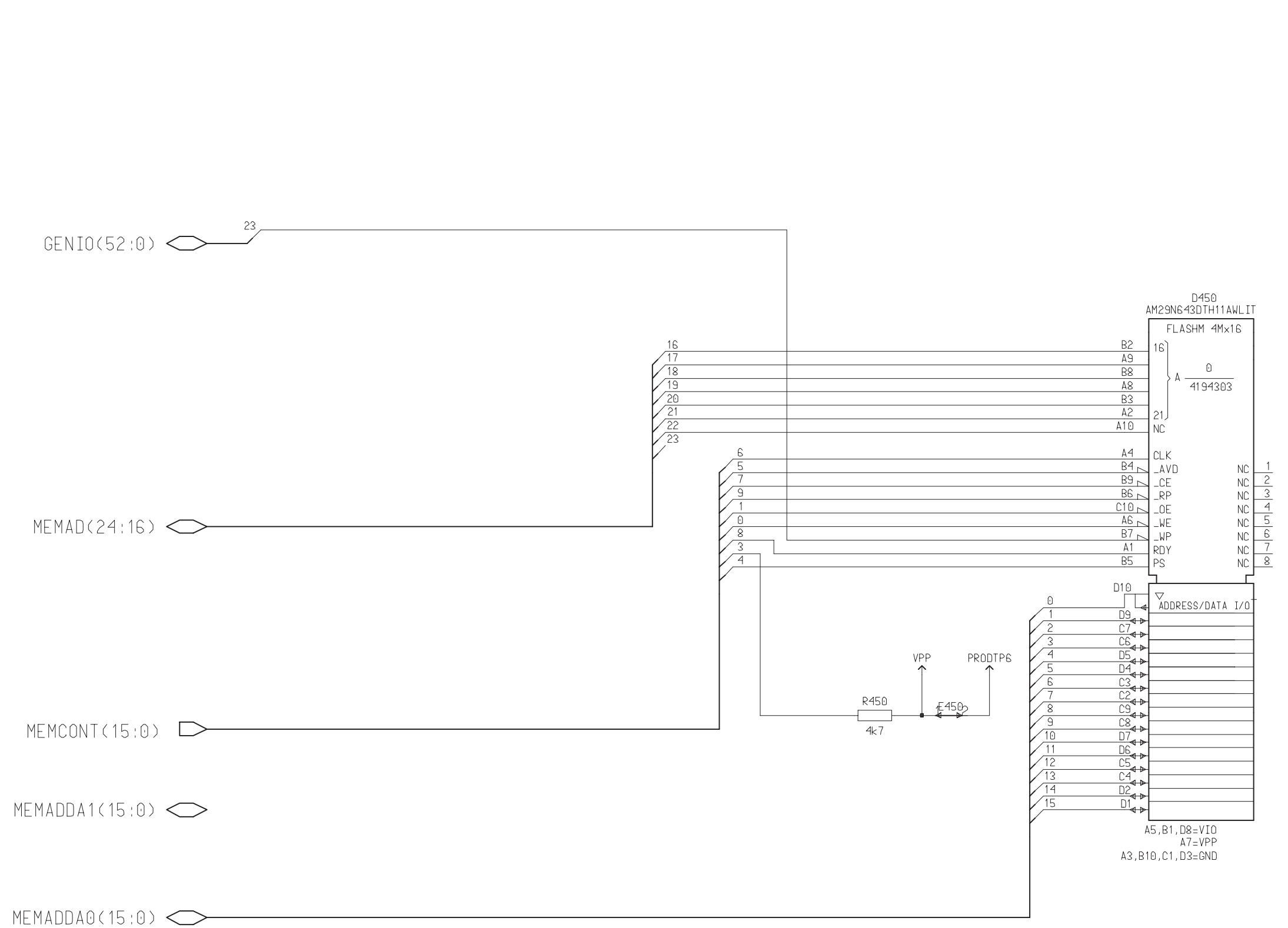
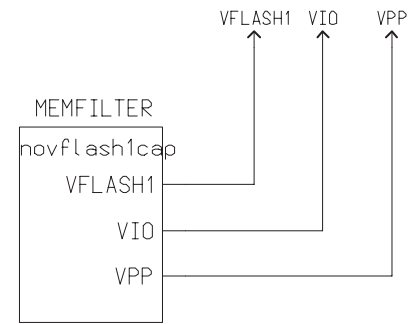

## Layout Diagram of LA5 – Top (Version 17)

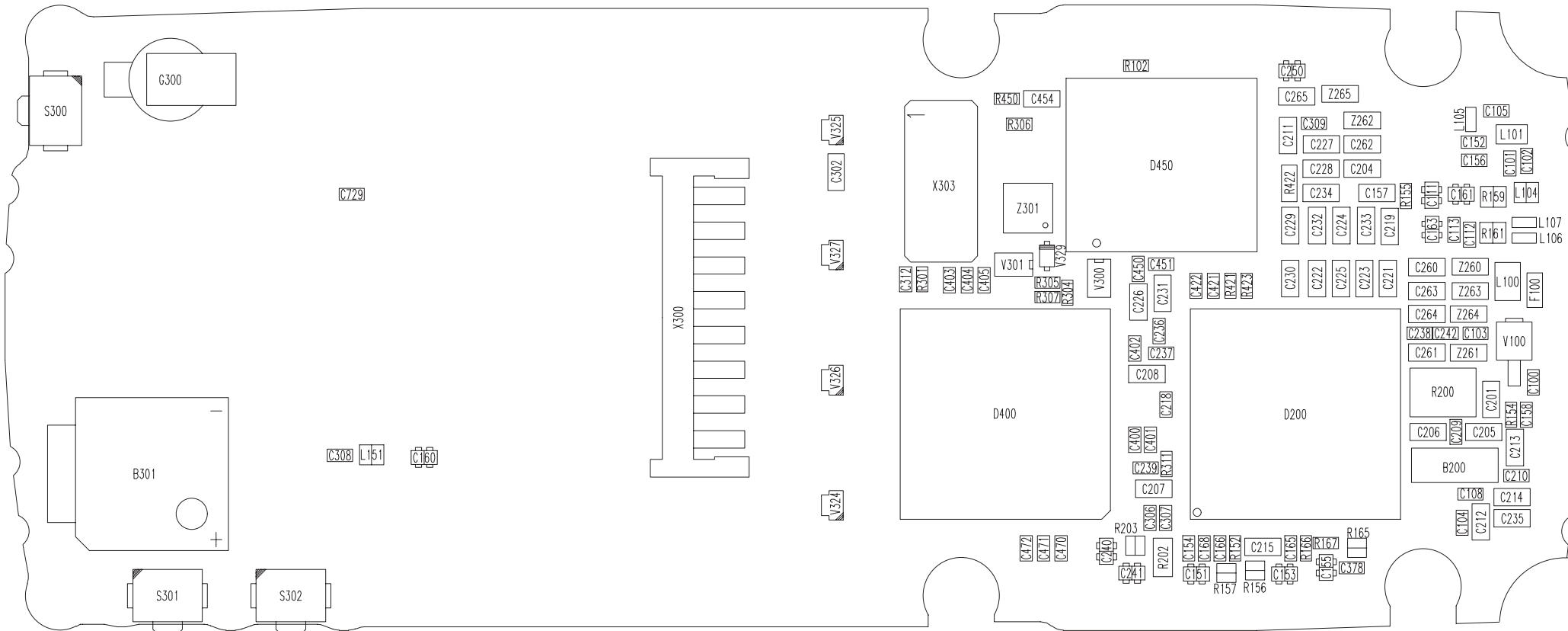

## Layout Diagram of LA5 – Bottom (Version 17)

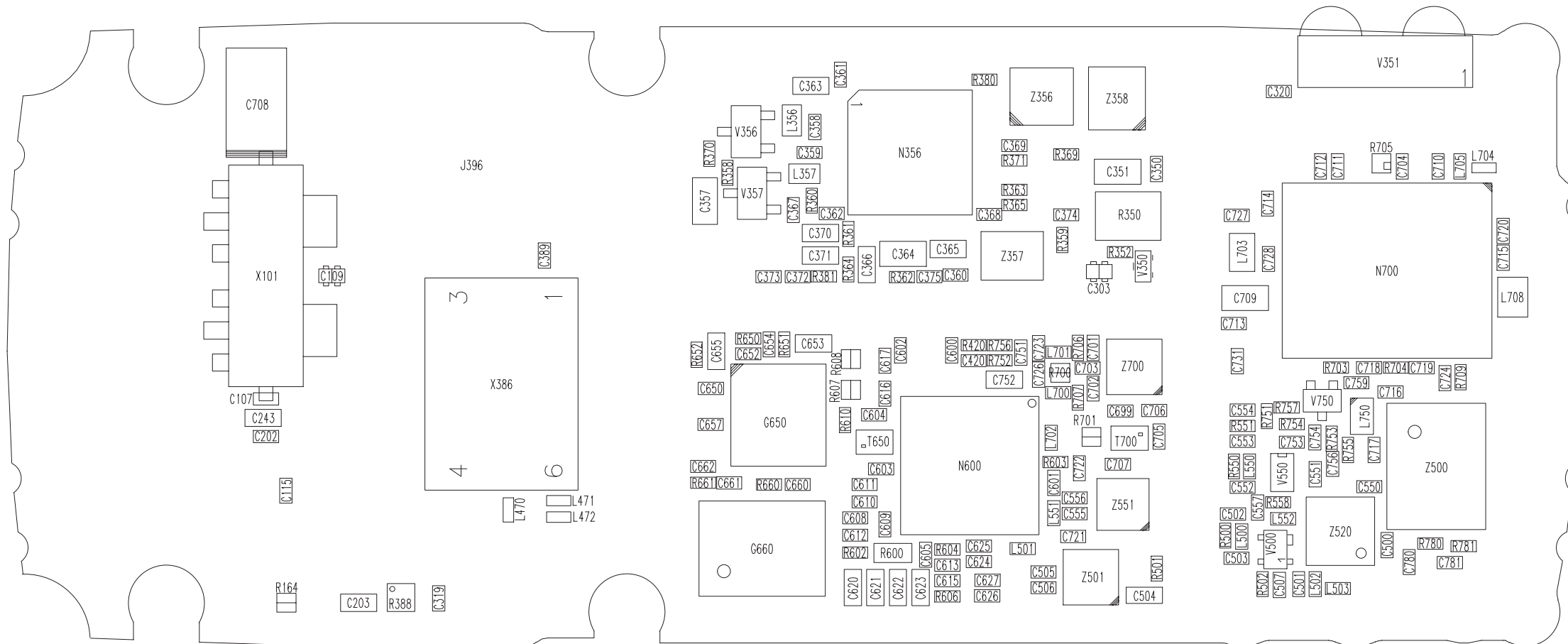

## Testpoints of LA5 – Bottom (Version 17)

